

DETAIL A

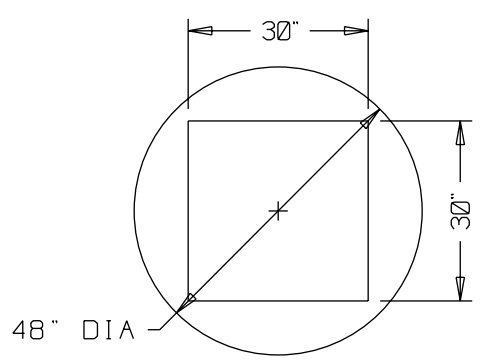

DETAIL B

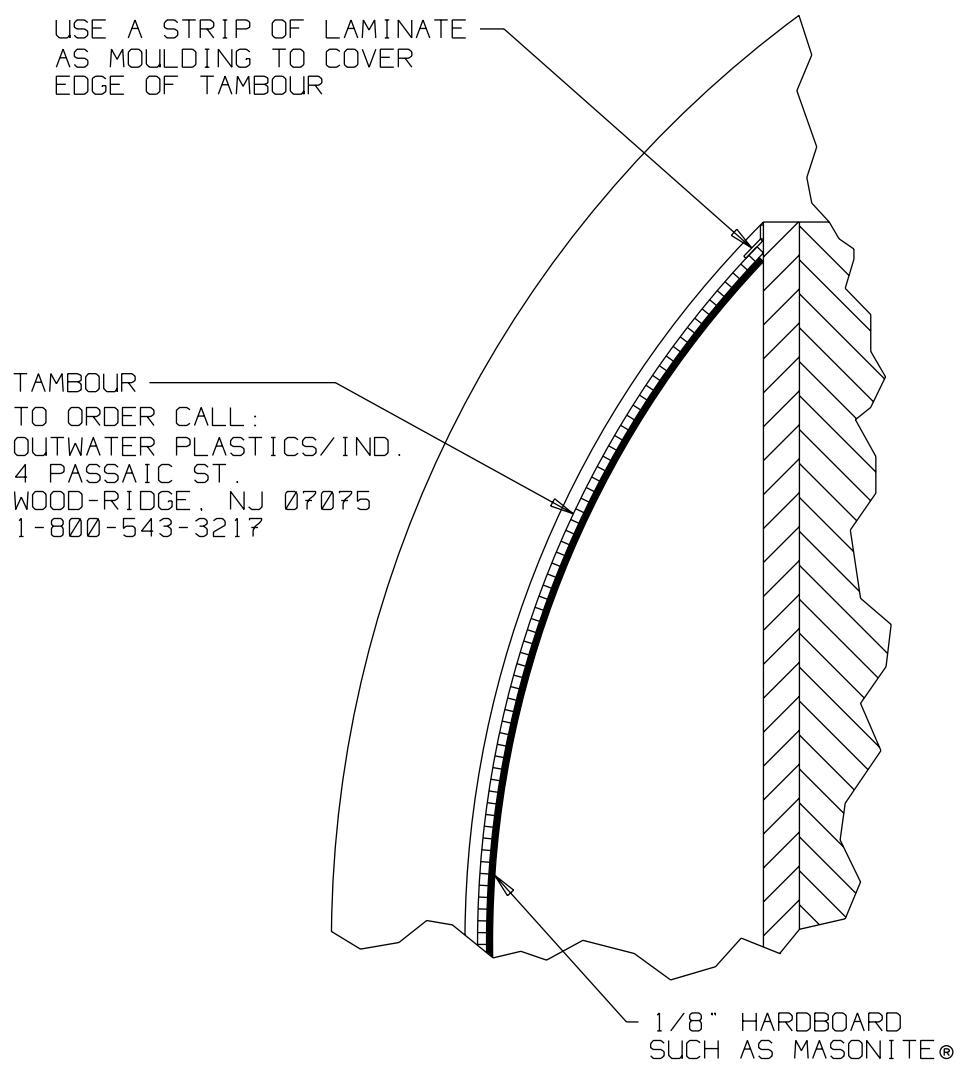

SECTION E-E

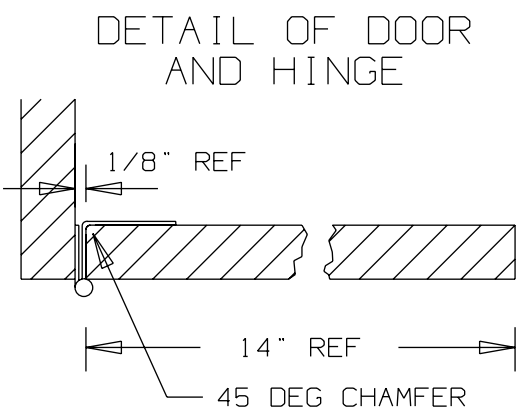

NOTE: CABINET HINGE SUCH AS AMEROCK® #BP5988-M3

DETAIL C

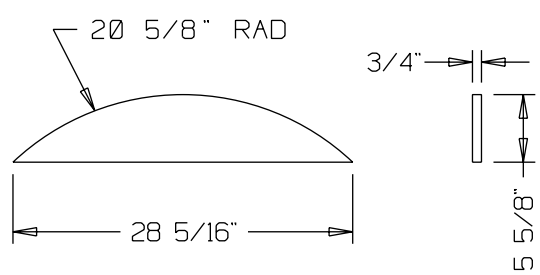

DETAIL D

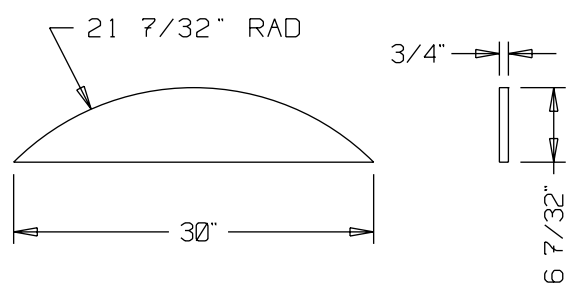

DETAIL F

© 1995 Accelerated Christian Education, Inc.
All rights reserved. Printed in the United States of America.
This publication may not be reproduced in whole or in part in any form or by any means without permission from Accelerated Christian Education, Inc.

ACCELERATED CHRISTIAN EDUCATION
OPTIONAL SUPERVISOR'S
STATION
DETAIL DRAWINGS

DWG. NO. 0010	REV. 950316-0	SHEET 3 OF 3
------------------	------------------	-----------------